Tennessee Comprehensive Assessment Program
TCAP

TNReady — Integrated Math I Part I

PRACTICE TEST

Student Name

Teacher Name



Tennessee Department of Education



Directions

This Practice Test booklet contains constructed-response items and selected-response items in Integrated Math I. For constructed-response items, write your answer in the space provided. For selected-response items, circle the correct answer(s).

You MAY use a calculator with all test items in this test booklet.

Sample A: Constructed-Response

The sum of two consecutive odd integers is 72.

1. Write an algebraic equation to determine the two integers.
2. What are the two integers?

Write your answers in the spaces provided.

1.

2.

Sample B: Selected-Response

Factor the polynomial:

$$s^2 + 12s + 32$$

- A. $(s + 4)(s - 8)$
- B. $(s - 2)(s + 16)$
- C. $(s + 4)(s + 8)$
- D. $(s + 16)(s + 2)$

Sample Answers

A.

1.

2.

- B.** A B C D



1. John has a goal to ride his bike at least 100 miles this summer. John has ridden 12 miles thus far. There are 40 days left in the summer.

Write an inequality to represent the average distance, d , in miles, John must ride each day for the rest of the summer to achieve his goal.

Write your answer in the space provided.

2. The Booneville History Museum had 25,000 visitors in 1980. The number of visitors has decreased by 2.5% each year since 1980.

Write a function $v(t)$ to represent the number of visitors to the Booneville History Museum t years after 1980.

Write your answer in the space provided.



3. Create the final image of $\triangle RST$ after reflecting first over the x -axis and then over the y -axis.

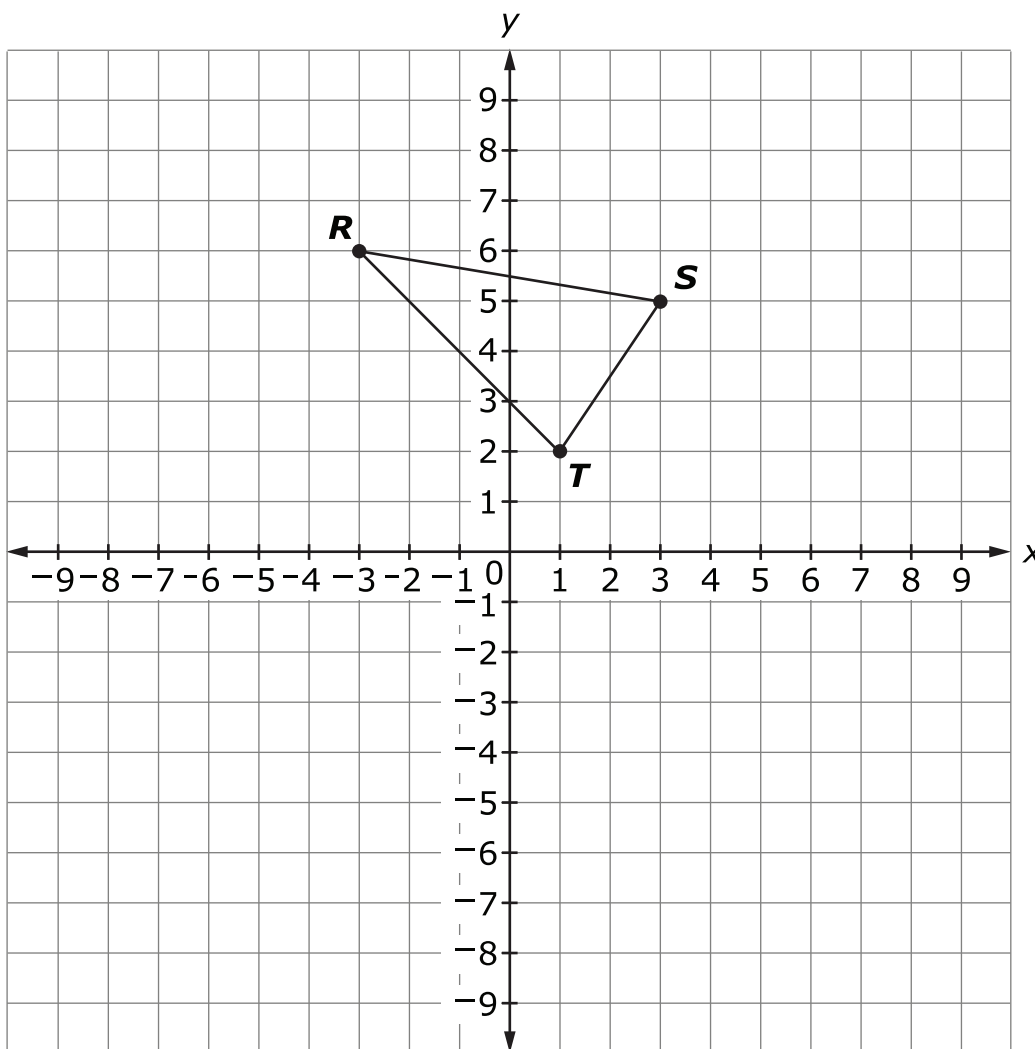



4. Makenna purchases a car for \$27,500. The value of the car will depreciate each year at a rate of 12.4%. What is the approximate equivalent monthly depreciation rate, to the nearest tenth of a percent?

Write your answer in the space provided.

5. The town of Krannert takes a census of its population every 4 years. The data are displayed in the table.

Year	Population
1996	25,480
2000	26,520
2004	27,560
2008	28,600
2012	29,640

What is the average yearly change in population in Krannert from 1996 to 2012?

- A. 16
- B. 260
- C. 1040
- D. 4160



6. Karen is buying supplies for a party. She plans to spend at least \$100 on food and at least \$50 on party favors. She can spend no more than \$250 total on food and party favors.

Graph the solution set to the amount of money Karen can spend on food, f , and party favors, p , and spend no more than \$250.

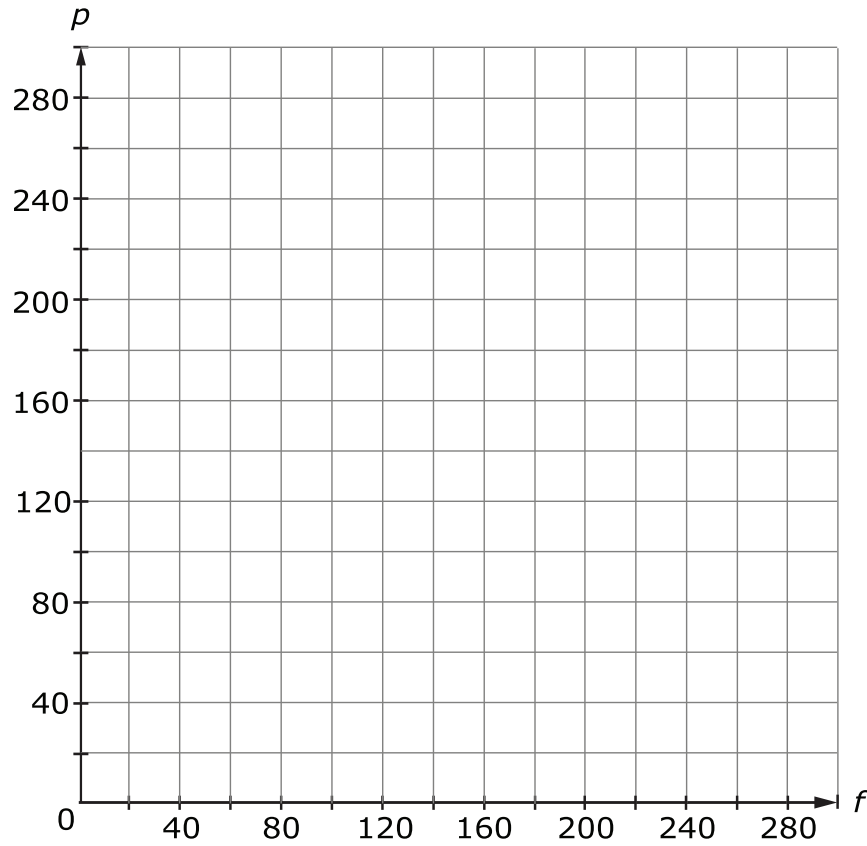



7. A proof is shown.

Given: $\triangle RST \cong \triangle PTS$, $\overline{SP} \parallel \overline{RT}$, and $\overline{SR} \parallel \overline{PT}$

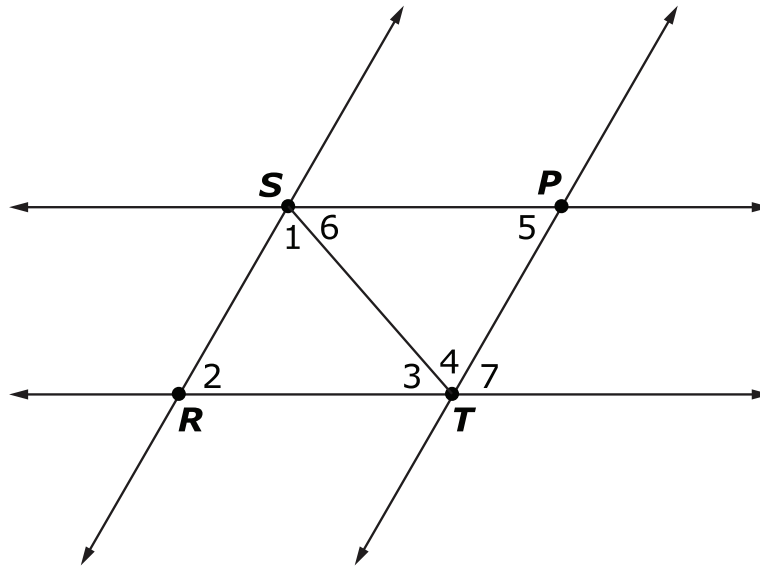

Prove: The sum of the measures of the interior angles of $\triangle RST$ is 180° .

Using the list of reasons provided, write the correct reason for each statement in the proof.

Statement	Reason
1. $\triangle RST \cong \triangle PTS$	1.
2. $\angle 1 \cong \angle 4$	2.
3. $\angle 7 \cong \angle 2$	3.
4. $m\angle 4 + m\angle 7 + m\angle 3 = 180^\circ$	4.
5. $m\angle 1 + m\angle 2 + m\angle 3 = 180^\circ$	5.

Reasons:

Substitution

Alternate interior angles are congruent.

Corresponding angles are congruent.

Angles 3, 4, and 7 form a line.

Given



8. Jamie deposits \$627 into a savings account. The account has an interest rate of 3.5%, compounded quarterly.

Write the function that gives the amount of money in dollars, $J(t)$, in Jamie's account t years after the initial deposit.

Write your answer in the space provided.

9. A rock is thrown from a cliff into a ravine.

The function $h(t) = -16t^2 + 192t + 2560$ describes the height, in feet, of the rock t seconds after it is thrown.

What is the height of the rock, in feet, 8 seconds after it is thrown?

Write your answer in the space provided.

10. The expression $760 + 22t$ represents the total number of students who graduated from Andrea's school t years after 1998.

Circle the value that **best** completes each sentence.

The number of students who graduate from Andrea's school each year is _____. [t 22 760 782]

The total number of students who graduated from Andrea's school through 1998 is _____. [t 22 760 782]



11. Harold’s car has a fuel tank with 12 gallons of fuel in it. The fuel efficiency of Harold’s car is 25 miles per gallon.

Write an equation to represent the amount of fuel remaining, f , in Harold’s car after driving m miles.

Write your answer in the space provided.

12. Rectangle $ABCD$ is shown.

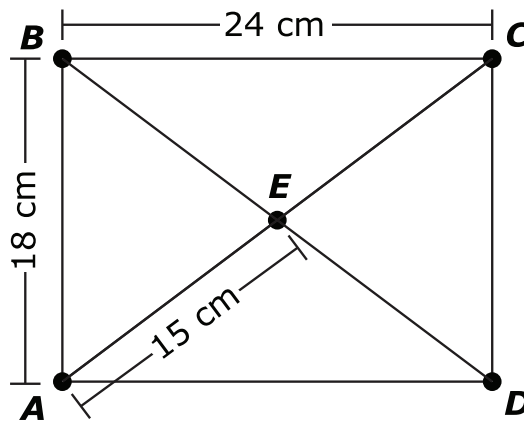

Circle the value that **best** completes each statement.

The measure of side CD is ____ cm. [15 18 24 30]

The measure of diagonal BD is ____ cm. [15 18 24 30]

The perimeter of triangle CDE is ____ cm. [33 48 54 57]



13. The expression $89,000(0.995)^t$ represents the population of a town t years after 1990.

Circle the values that **best** complete the sentence below.

The population of the town by each year.

Box A	Box B
increases	0.5%
decreases	0.995%
	5%
	99.5%
	995%

Tennessee Comprehensive Assessment Program
TCAP

TNReady — Integrated Math I Part II

PRACTICE TEST

Student Name

Teacher Name



Tennessee Department of Education



Directions

Subtest 1 of this Practice Test booklet contains constructed-response items and selected-response items in Integrated Math I. For constructed-response items, write your answer in the space provided. For selected-response items, circle the correct answer(s).

You MAY NOT use a calculator in Subtest 1 of this test booklet.

Sample A: Constructed-Response

The sum of two consecutive odd integers is 72.

1. Write an algebraic equation to determine the two integers.
2. What are the two integers?

Write your answers in the spaces provided.

1.

2.

Sample B: Selected-Response

Factor the polynomial:

$$s^2 + 12s + 32$$

- A. $(s + 4)(s - 8)$
- B. $(s - 2)(s + 16)$
- C. $(s + 4)(s + 8)$
- D. $(s + 16)(s + 2)$

Sample Answers

A.

1.

2.

- B.** (A) (B) ● (D)



1. Select **all** tables that could represent a function.

A.

x	y
-4	8
-1	2
1	-3
4	9

B.

x	y
0	3
2	3
4	5
6	5

C.

x	y
1	-1
3	-4
3	-6
7	-9

D.

x	y
5	1
5	2
5	3
5	4

E.

x	y
-3	0
-2	0
-1	0
0	0



2. Grace and her brother Sid want to raise money to go to band camp. Their parents have agreed to help them earn up to \$400 by paying them \$25 when one of them mows the lawn and \$10 for each hour that one of them babysits their younger brother. They will have to do a combination of both chores in order to earn the money.

Select the equation that represents the number of lawns they can mow, m , and hours they can babysit, b , to earn \$400.

- A. $10m + 25b = 400$
- B. $10m - 25b = 400$
- C. $25m + 10b = 400$
- D. $25m - 10b = 400$



3. Consider the figure shown:

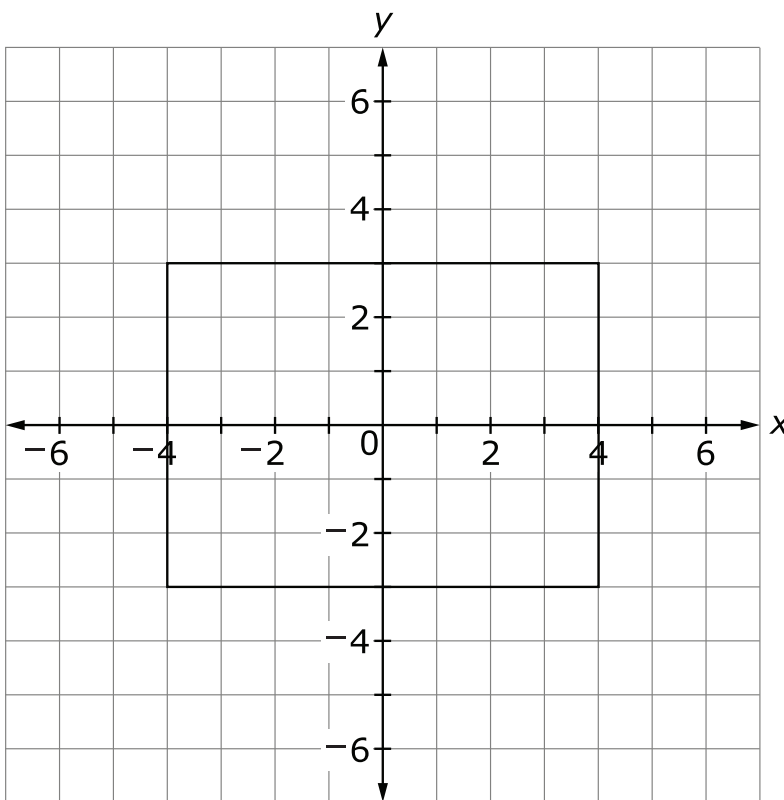

Which description **best** explains how this figure can be transformed onto itself?

- A. by reflecting across the x -axis only
- B. by reflecting across the y -axis only
- C. by rotating the figure 180° about the origin only
- D. by reflecting across the x -axis, or reflecting across the y -axis, or rotating 180° about the origin



4. Two of Mr. Evan’s Earth science classes have 23 students each. Box plots for recent test scores for these two classes are displayed.

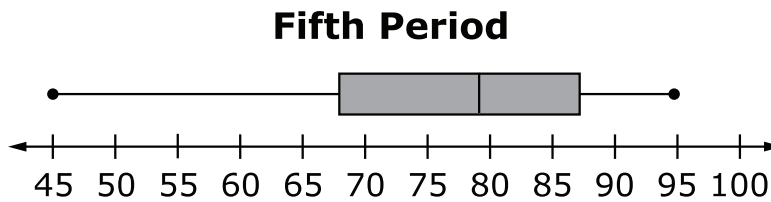
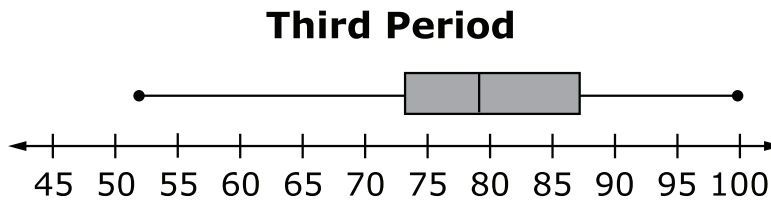

Which statement about the scores is true?

- A. The means of the two sets of data are equal.
 - B. The lower quartiles of the two sets of data are the same.
 - C. More students in third period than in fifth period scored an 87 or above.
 - D. The number of students in third period who scored from 73 to 79 equaled the number of students in fifth period who scored from 68 to 79.
5. The fourth term of a sequence is 108. Each term after the first is 3 times the previous term.

Write an explicit expression that models the general term of the sequence $f(n)$.

Write your answer in the space provided.



6. The balance of an account after t years can be found using the expression $6000(1.02)^t$ where the initial balance was \$6000.

By what percent does the account increase annually?

- A. 0.02%
- B. 1.02%
- C. 2%
- D. 102%

7. The triangles QTP and SPT are shown. Line RM is the perpendicular bisector of line segment PT and intersects line segment PT at point M .

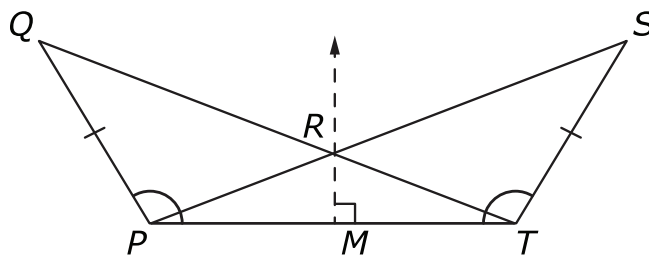

Which transformation would imply that $\triangle QTP \cong \triangle SPT$?

- A. horizontal translation the length of \overline{PR}
- B. horizontal translation the length of \overline{PT}
- C. reflection over \overline{RM}
- D. reflection over \overline{SP}



8. For $\triangle RST$ and $\triangle UVW$, sides \overline{RS} , \overline{RT} , and \overline{ST} are congruent to sides \overline{VW} , \overline{VU} , and \overline{WU} , respectively.

Circle the word, phrase, or label that **best** completes each statement.

This proves that there _____ [could or could not must cannot]
be a set of rigid motions that has pre-image $\triangle RST$ and image $\triangle UVW$.

This also proves that angle RST is congruent to angle _____
[UVW VWU WUV].

9. Which pair **best** represents a causation relationship?
- A. a child's age and shoe size
 - B. the number of ice cream cones sold and the amount of sunscreen sold
 - C. the temperature at a football game and the number of hot drinks sold
 - D. the number of people attending a ballgame and the length of the ballgame

**Directions**

Subtest 2 of this Practice Test booklet contains constructed-response items and selected-response items in Integrated Math I. For constructed-response items, write your answer in the space provided. For selected-response items, circle the correct answer(s).

You MAY use a calculator in Subtest 2 of this test booklet.

- 10.** A system of functions is given.

$$f(x) = -x^2 - 2x + 6$$
$$g(x) = 2x^2 + 5x + 3$$

Select all values of x , to the nearest tenth, for which $f(x) = g(x)$.

- A.** -2.7
 - B.** -1.8
 - C.** -0.6
 - D.** 0.4
 - E.** 4.1
 - F.** 5.1
 - G.** 7.0
- 11.** The function $p(t) = 3(2)^t$ represents the population of a certain type of bacteria after t days.

What is the population of the bacteria after 5 days?

Write your answer in the space provided.



- 12.** The equation $A = 1750(1.04)^t$ represents an account balance t years after the account was created.

Which statement is correct?

- A.** The account balance will decrease 0.04% each year.
- B.** The account balance will increase 0.04% each year.
- C.** The account balance will decrease 4% each year.
- D.** The account balance will increase 4% each year.

- 13.** Solve the inequality.

$$4x - 7 \geq \frac{-12x + 14}{4}$$

- A.** $x \geq 3\frac{1}{2}$
- B.** $x \leq 3\frac{1}{2}$
- C.** $x \geq 1\frac{1}{2}$
- D.** $x \leq 1\frac{1}{2}$



14. One end of a metal spring is attached to a ceiling. The other end of the spring hangs down.

The table displays the length of the spring when different masses are tied to the end of the spring that hangs down.

Mass Tied to Spring (kg)	Length of Spring (cm)
0	439.0
2	439.1
4	439.2
6	439.3

How much longer does the spring become with each extra kilogram of mass that is tied to it?

- A. 0.01 cm
B. 0.05 cm
C. 0.1 cm
D. 0.5 cm
15. The first term in a sequence is 8. Consecutive terms in the sequence have a common difference. The fourth term in the sequence is 17.

Select the function, $f(n)$, that represents this sequence for $n \geq 1$.

- A. $f(1) = 8$
 $f(n+1) = f(n) - 3$
- B. $f(1) = 8$
 $f(n+1) = f(n) + 3$
- C. $f(1) = 8$
 $f(n+1) = \frac{9}{4}f(n)$
- D. $f(1) = 8$
 $f(n+1) = \frac{17}{8}f(n)$



16. The height, in inches, of each student in Megan's algebra class is shown.

72	72	71	70	70
70	69	67	66	65
65	65	64	63	62
62	62	59	58	54

Select **all** measures that will be affected if a student who is 77 inches tall joins the class.

- A. interquartile range
- B. mean
- C. median
- D. range



17. The graph of the function $f(x)$ and the equation of a different function, $g(x)$, are given.

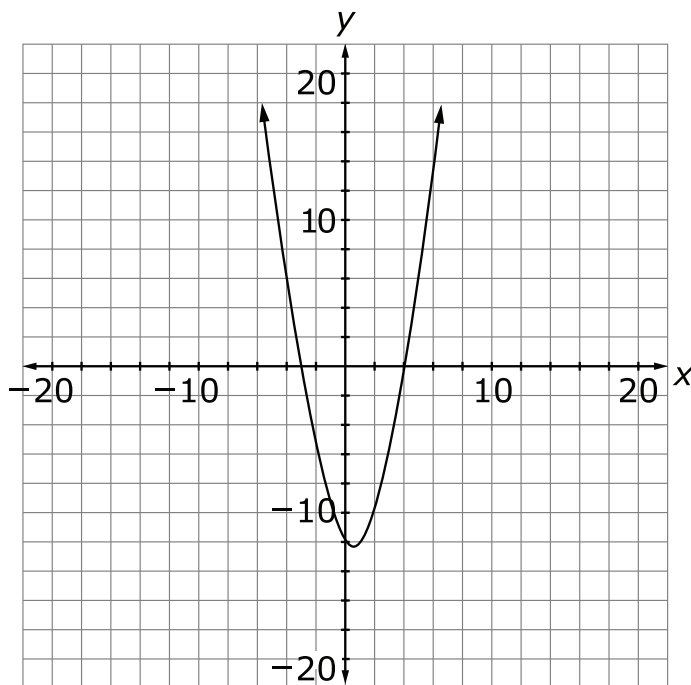

$$g(x) = 2x - 2$$

Select **all** values of x for which $f(x) = g(x)$.

- A. -3
- B. -2
- C. 0
- D. 2
- E. 5
- F. 8